



Utech Projects Pvt. Ltd.



OIL / GAS FIRED BOILER



- ◆ Higher Thermal Efficiency of more than 88 % on NCV with Heat recovery
- ◆ 3 Pass Fully Wet Back
- ◆ Package Skid Mounted
- ◆ Fully Automatic with turndown ratio of 1:4
- ◆ Pressure 10.54 Kgs/cm² to 17.5 Kgs/cm². OR to suit client's requirement

IBR OIL/GAS FIRED BOILERS

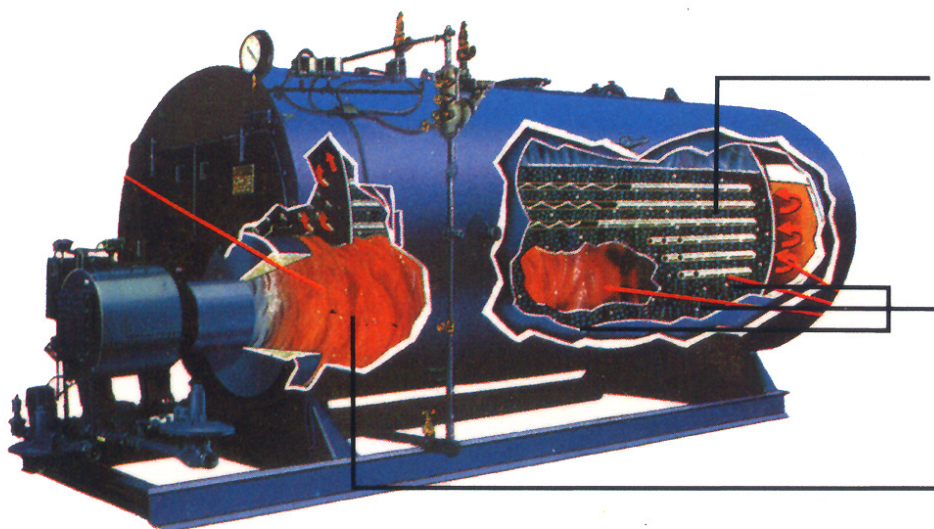

1. Fully wet-back design effectively absorbs radiant heat into the water, keeping tube ends and rear side of boiler cooler than in dry back design.
2. Three passes extract maximum usable heat from the fuel.
3. Large water-surrounded furnace assures complete combustion and heat absorption without Flame impingement.

CONSTRUCTION

ENERGYPACK Boilers are three pass wet back, horizontal, smoke tube type fusion welded. Boilers are made to IBR/DIN/BS/ASME-code. Components are engineered for maximum safety, highest efficiency, dependability and quiet operation. Wet back models eliminate rear end refractory and its inherent maintenance cost, reduces stress of rear tube sheet and ligament cracking, radiant heat is eliminated, lengthening tube life and reducing heat loss from rear turnaround.

Unique design features

- ◆ Fully automatic pressure jet Burner – Boiler furnace design suitable for Imported Weishaupt/ Reillo & Indian modulating burner.
- ◆ Efficiency enhancement – Optional accessories such as air preheater and economizer can be Integrated with the main unit.
- ◆ Automation with Programmable Logic Controllers (PLC) with Supervisory Control and Data Acquisition (SCADA) system can also be offered at an extra cost. Standard boilers are supplied with fully automatic operation with safety interlocks & alarm.

MODEL	EBPL	EBPL	EBPL	EBPL	EBPL	EBPL	EBPL	EBPL	EBPL	EBPL	EBPL	EBPL	EBPL	EBPL	EBPL
	0-I	0-II	0-III	0-IV	0-V	0-VI	0-VII	0-VIII	0-IX	0-X	0-XI	0-XII	0-XIII	0-XIV	0-XV
STEAM OUTPUT TONS/HR (FROM & AT 100 ^o .C)	0.5	0.75	1.0	1.5	2.0	2.5	3.0	3.5	4.0	5.0	6.0	8.0	10.0	12.0	14.0
OVERALL LENGTH MTRS	3.80	4.00	4.20	4.30	4.60	5.10	5.25	5.54	5.85	6.20	7.00	8.00	8.80	9.50	9.50
OVERALL WIDTH MTRS	2.20	2.20	2.35	2.45	2.55	2.70	2.75	2.77	2.93	3.12	3.20	3.30	3.60	3.90	4.00
OVERALL HEIGHT MTRS	3.00	3.10	3.20	3.37	3.50	3.67	3.75	3.80	4.00	4.10	4.20	4.35	4.50	5.00	5.20
FLUE GAS DUCT SIZE MM	225	225	250	250	300	300	300	300	400	400	475	550	650	750	800
FURNACE OIL KGS/HR	32	48	64	96	128	160	192	224	256	320	384	512	640	768	896
NATURAL GAS NM ³ /HR	36	54	72	108	114	180	216	252	288	360	432	576	720	864	1008
FUEL - Furnace Oil – 9650 Kcal/Kgs. Natural Gas – 8500 Kcal/NM³															

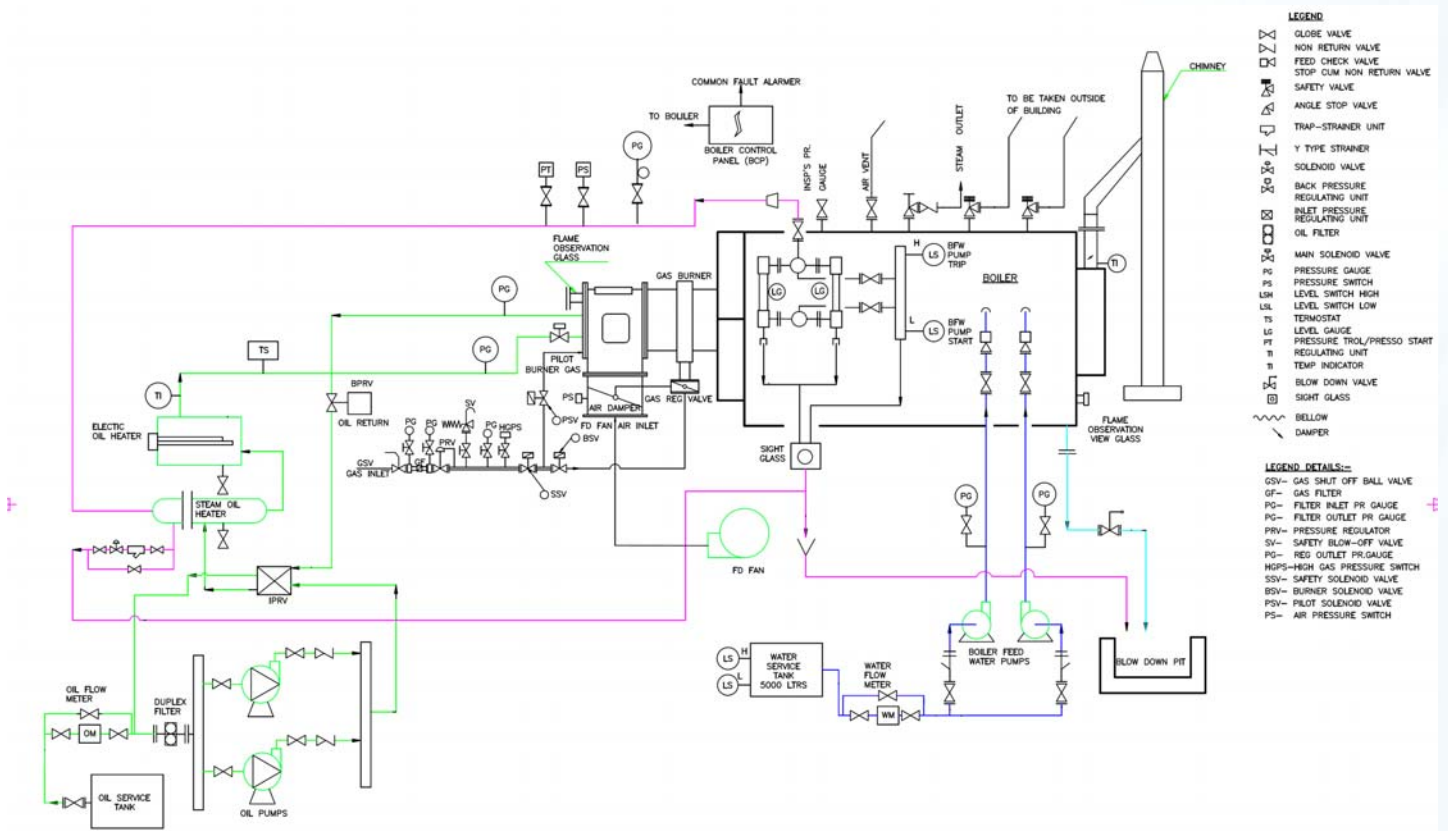

STANDARD FLOW DIAGRAM OIL/GAS FIRED BOILER

ERECTION & MAINTENANCE

“Energypack” Boilers are shop assembled and no special foundation is required. Each unit is a complete package ready for quick installation and connection for your service lines. For easy internal maintenance and cleaning, Manholes & Mudholes are well placed. Boiler tubes are easy to inspect as hinged front & back doors enable quick and easy Maintenance, inspection or cleaning. Spares are easily available.

PERFORMANCE

Efficiency of oil fired boiler on N.C.V. is 88% with B.S./DIN tolerance on a very wide working range and higher figures are not un-common. Steam of high purity and dryness fraction is generated as Heat Transfer surfaces in the boiler is judiciously accommodated.

CUSTOMISED INSTALLATION

Our boiler is tested before shipment including a complete check of controls. Energypack offer start-up adjustments to your fuel and steam load. Special training of operator is available.

STEAM RAISING TIME

After overnight shut down only twenty minutes are required to raise steam to maximum continuous rating From 5 Kg/cm² to 10.54 Kg/cm² (150 psig) in standard package smoke tube boilers.

OTHER PRODUCTS

IBR & NON IBR STEAM BOILERS

- ◆ Self Supported Chimneys.
- ◆ Hot water Boilers.
- ◆ Heat Exchangers (TEMA).
- ◆ Pressure Vessels (ASME).
- ◆ Waste Heat Boilers.
- ◆ Electrode Boilers.
- ◆ Dewaxing Autoclave Boilers.
- ◆ Incinerators.



Hot Air Circulation Autoclave



Explosion Proof Control Panel



Self Supported Chimney



Utech Projects Pvt. Ltd.

Authorised Exclusive Marketing Agency

of



M/S ENERGOPACK BOILERS PVT LTD

Office :
UTECH PROJECTS PVT LTD.

9/10, Dattani 5A, Shivaji Road,
Kandivali (West), Mumbai - 400067.
Maharashtra, India.

Telefax: +91 - 22 - 28642832 / 28642833

E mail : utechprojects@gmail.com
sales@utechprojects.com

Website : www.utechprojects.com



Registered Office & Works of Principle Manufacturer:
ENERGOPACK BOILERS PVT LTD.

24-P, Baska - Uijeti Road, Village Uijeti,
Taluka: Halol, Jilla, Panchmahal, Gujarat - 389350.

Telefax: +91 - 02676 - 247055 / 247247
Mumbai Off No: +91 22 26854233 / 26854957

E mail : uday@energypackboilers.com
response@energypackboilers.com

Website : www.energypackboilers.com